



AIR CONTROL
MODEL 0400
FIRE DAMPER

INSTALLATION, OPERATION
AND MAINTENANCE MANUAL

Index

| | Page |
|---|-----------|
| Introduction and Health & Safety | 3 |
| Circular fire damper – Model 0400MAN | |
| Two hour flexible wall | 4 |
| Two hour rigid wall | 5 |
| Circular fire damper – Model 0400FME | |
| Two hour flexible wall | 6 |
| Two hour rigid wall | 7 |
| Operation and Maintenance | |
| Model 0400MAN | 8 |
| Model 0400FME | 9 |
| Wiring information | |
| Model 0400FME | 10 |
| Spacing around damper installations | 11 |
| DW145 Fire Damper Certificate | 12 |



Introduction

Advanced Air (UK) Ltd have been manufacturing a comprehensive range of fire dampers and fire smoke dampers since 1975. We have always taken pride in our products and tested to the highest standards, originally to BS476 and now more stringent testing to CE labelling under the Construction Product Regulation which was introduced 1st July 2013.

All our fire, fire smoke and smoke control dampers have been tested to BS EN 1366-2 and BS EN 1366-10. This is to cover a variety of installations used on sites today. Under CE labelling all dampers must follow the Product Standards BS EN 15650 and BS EN 12101-8 which ensures the product is consistent and supplied to the same specification and standard as tested. Any deviation or changes from the installations in this manual would require the dampers to be subject to a new test or approval sought from Local Building Control.

In line with product standards we are pleased to offer this installation manual covering installation, operation and maintenance instructions together with Health and Safety information. We have also included within this manual an example of the Fire Damper Certificate DW145 Inspection and Handover Check Sheet which is to be completed by the installer. A separate certificate is required per damper.

The installation contained in this manual cover most installation on site. However, there are still installation which Advanced Air (UK) Ltd have not yet tested. We are continually reviewing requirements and continuously developing the products. As additional installation tests are carried out and classified, installations will be added to this manual, and the Declaration of Performance (DoP) updated accordingly.

Health and Safety

Any instruction contained within this manual must be undertaken by competent trained personnel. When completing the installation standard PPE should be used, steel toe cap boots, hard hat, gloves, protective eyewear along with any other specific site or material instructions.

The size and weight of dampers vary, and it may require two or more persons to safely handle and move them. Do not lift the dampers by the blades or the actuator.

For the installation of dampers at high level, the correct lifting equipment shall be used in accordance with the Work at Height Regulations 2005 and specific site rules.

All waste materials should be collected and disposed of defined by the suppliers.

FIRE – 0400MAN CIRCULAR FIRE DAMPER IN FLEXIBLE SUPPORTING CONSTRUCTION

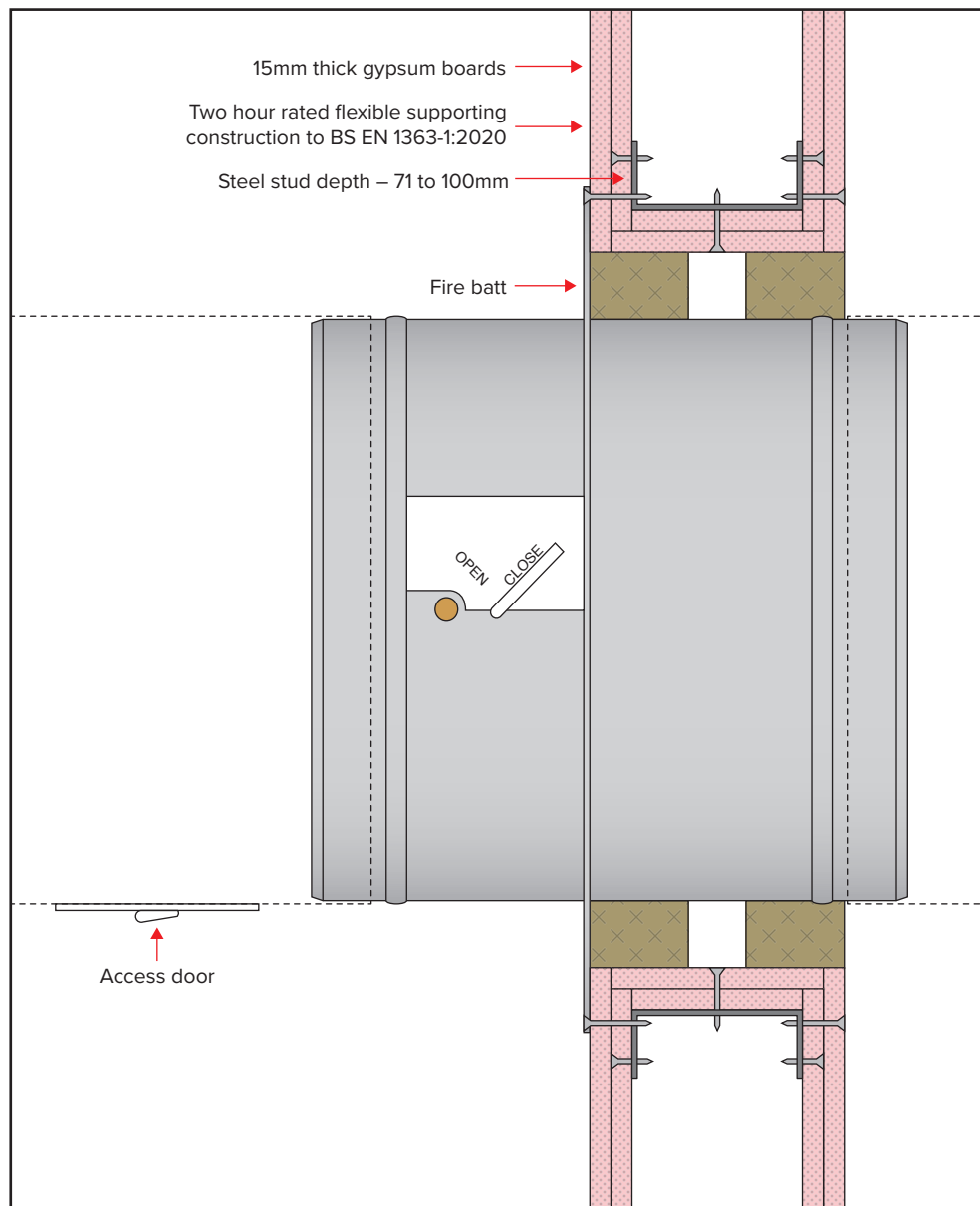

Preparation

- 1 Ensure that the damper is kept in a clean dry environment and that there is no damage to the damper.
- 2 Work out the opening size to be cut by adding 55mm to the duct diameter and cut a square hole to that size, see adjacent table.

| Nom. duct diameter | Opening size |
|--------------------|--------------|
| 100mm | 155 x 155mm |
| 125mm | 180 x 180mm |
| 150mm | 205 x 205mm |
| 160mm | 215 x 215mm |
| 200mm | 255 x 255mm |
| 250mm | 305 x 305mm |
| 300mm | 355 x 355mm |
| 315mm | 370 x 370mm |

Installation sequence

- 3 The drywall will consist of two layers of 15mm plasterboard on each side of steel studwork with an optional 50mm mineral wool insulation. The opening will be a letterbox construction with overlapping layers of plasterboard.
- 4 The damper should be mounted in the opening with the fixing flange (access side) flush with the wall.
- 5 Confirm that the blade is horizontal, and the handle is on the RH or LH. The flange can then be secured to the wall using M3.5 x 38mm drywall screws which are to pierce the steel channel. Ensure that all the pre-drilled holes are populated.
- 6 The gap between the damper and the wall opening will need filling with two layers of 50mm thick 140kg/m³ fire batt cut to interference fit and pushed into place. All cut edges must be sealed with a fire batt sealant to BS EN 13501-2. A fire rated intumescent mastic to BS EN 13501-2 shall be applied to each joint.
- 7 The galvanised mild steel ductwork connecting to the damper spigots should overlap by 30mm, leaving a 10mm clearance for any duct expansion in a fire situation.
- 8 The galvanised mild steel ductwork connections must be sealed with an approved galvanised mild steel ductwork sealer and fixed with low resistance fixings such as aluminium rivets that will melt at high temperature allowing the duct to break away without affecting the integrity of the installation.
- 9 The connecting galvanised mild steel ductwork must be independently supported within one metre of the connections and have been installed in accordance with DW144.
- 10 An access door should be fitted on the access side of the damper for inspection and maintenance.
- 11 When the damper installation is complete the operation of the damper should be checked.
- 12 Complete DW145 Fire Damper Certificate.

PRODUCT **0400MAN**

APPLICATION **FLEXIBLE SUPPORTING CONSTRUCTION**

CLASSIFICATION REPORT NO. **P105424-1003**

CLASSIFICATION **E120 (VE I ↔ O)**

TESTED INSTALLATION METHOD SHOWN. DIFFERING INSTALLATION METHODS TO THIS MUST BE APPROVED BY THE BUILDING CONTROL AUTHORITY (BCA) BEFORE PROCEEDING.

FIRE – 0400MAN CIRCULAR FIRE DAMPER IN RIGID SUPPORTING CONSTRUCTION

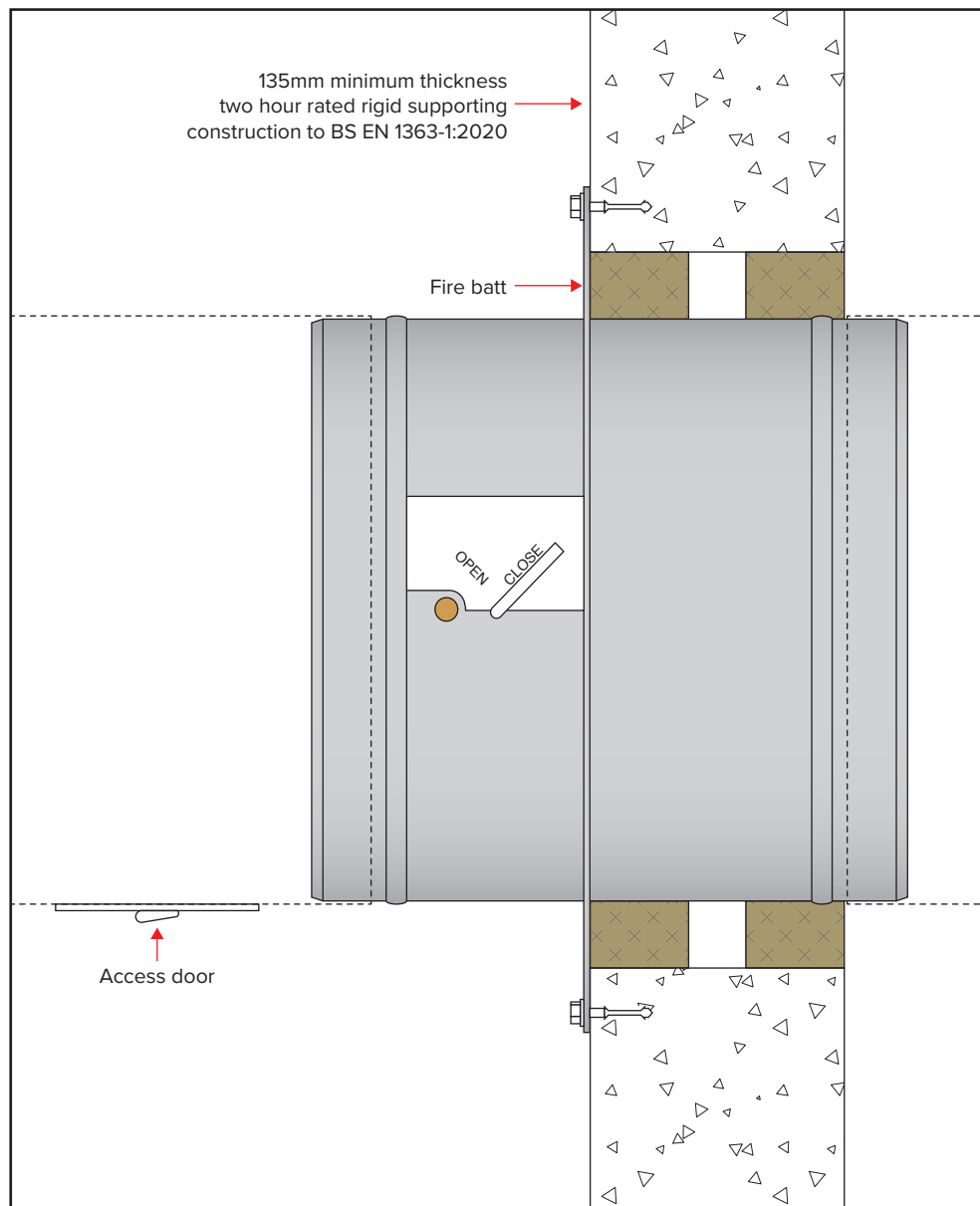

Preparation

- 1 Ensure that the damper is kept in a clean dry environment and that there is no damage to the damper.
- 2 Work out the opening size to be cut by adding 55mm to the duct diameter and cut a square hole to that size, see adjacent table.

| Nom. duct diameter | Opening size |
|--------------------|--------------|
| 100mm | 155 x 155mm |
| 125mm | 180 x 180mm |
| 150mm | 205 x 205mm |
| 160mm | 215 x 215mm |
| 200mm | 255 x 255mm |
| 250mm | 305 x 305mm |
| 300mm | 355 x 355mm |
| 315mm | 370 x 370mm |

Installation sequence

- 3 The damper should be mounted in the opening with the fixing flange (access side) flush with the wall.
- 4 Confirm that the blade is horizontal, and the handle is on the RH or LH. The flange can then be secured to the wall using fire resistant steel fixings. Ensure that all the pre-drilled holes are populated.
- 5 The gap between the damper and the wall opening will need filling with two layers of 50mm thick 140kg/m³ fire batt cut to interference fit and pushed into place. All cut edges must be sealed with a fire batt sealant to BS EN 13501-2. A fire rated intumescent mastic to BS EN 13501-2 shall be applied to each joint.
- 6 The galvanised mild steel ductwork connecting to the damper spigots should overlap by 30mm, leaving a 10mm clearance for any duct expansion in a fire situation.
- 7 The galvanised mild steel ductwork connections must be sealed with an approved galvanised mild steel ductwork sealer and fixed with low resistance fixings such as aluminium rivets that will melt at high temperature allowing the duct to break away without affecting the integrity of the installation.
- 8 The connecting galvanised mild steel ductwork must be independently supported within one metre of the connections and have been installed in accordance with DW144.
- 9 An access door should be fitted on the access side of the damper for inspection and maintenance.
- 10 When the damper installation is complete the operation of the damper should be checked.
- 11 Complete DW145 Fire Damper Certificate.

PRODUCT **0400MAN**

APPLICATION **RIGID SUPPORTING CONSTRUCTION**

CLASSIFICATION REPORT NO. **P105424-1003**

CLASSIFICATION **E120 (VE I ↔ O)**

TESTED INSTALLATION METHOD SHOWN. DIFFERING INSTALLATION METHODS TO THIS MUST BE APPROVED BY THE BUILDING CONTROL AUTHORITY (BCA) BEFORE PROCEEDING.

FIRE & SMOKE – 0400FME CIRCULAR DAMPER IN FLEXIBLE SUPPORTING CONSTRUCTION

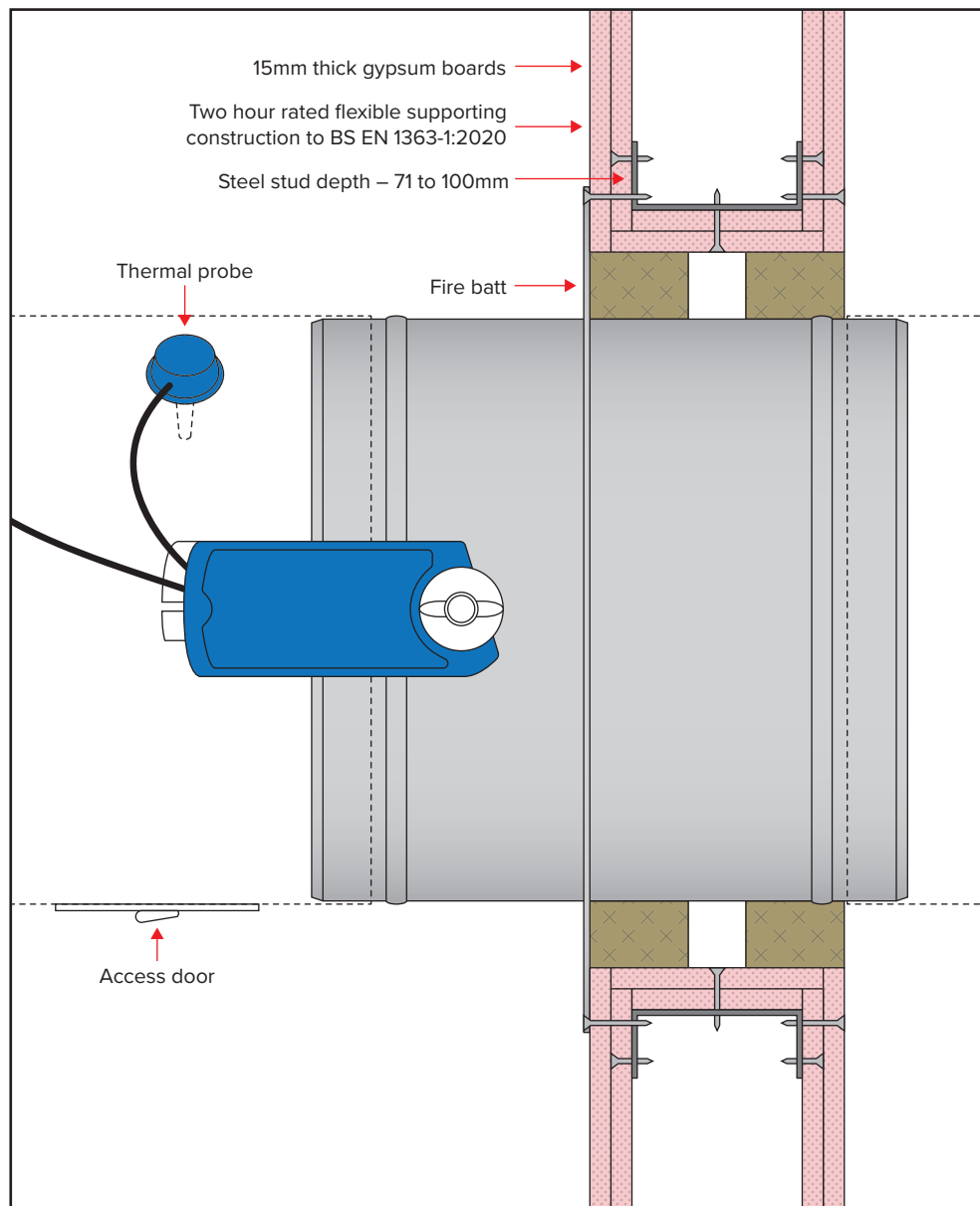

Preparation

- 1 Ensure that the damper is kept in a clean dry environment and that there is no damage to the damper.
- 2 Work out the opening size to be cut by adding 55mm to the duct diameter and cut a square hole to that size, see adjacent table.

| Nom. duct diameter | Opening size |
|--------------------|--------------|
| 100mm | 155 x 155mm |
| 125mm | 180 x 180mm |
| 150mm | 205 x 205mm |
| 160mm | 215 x 215mm |
| 200mm | 255 x 255mm |
| 250mm | 305 x 305mm |
| 300mm | 355 x 355mm |
| 315mm | 370 x 370mm |

Installation sequence

- 3 The drywall will consist of two layers of 15mm plasterboard each side of steel studwork with an optional 50mm mineral wool insulation. The opening will be a letterbox construction with overlapping layers of plasterboard.
- 4 The damper should be mounted in the opening with the fixing flange (access side) flush with the wall.
- 5 Confirm that the blade is horizontal, and the actuator is on the RH or LH. The flange can then be secured to the wall using M3,5 x 38mm drywall screws which are to pierce the steel channel. Ensure that all the pre-drilled holes are populated.
- 6 The gap between the damper and the wall opening will need filling with two layers of 50mm thick 140kg/m³ fire batt cut to interference fit and pushed into place. All cut edges must be sealed with a fire batt sealant to BS EN 13501-2. A fire rated intumescent mastic to BS EN 13501-2 shall be applied to each joint.
- 7 The galvanised mild steel ductwork connecting to the damper spigots should overlap by 30mm, leaving a 10mm clearance for any duct expansion in a fire situation.
- 8 The galvanised mild steel ductwork connections must be sealed with an approved galvanised mild steel ductwork sealer and fixed with low resistance fixings such as aluminium rivets that will melt at high temperature allowing the duct to break away without affecting the integrity of the installation.
- 9 The thermal probe should be fitted in the connecting galvanised mild steel ductwork, up to 400mm away from the wall. Drill a 11mm hole, insert the thermal probe and secure with two pro points. Template and screws supplied.
- 10 The connecting galvanised mild steel ductwork must be independently supported within one metre of the connections and have been installed in accordance with DW144.
- 11 An access door should be fitted on the access side of the damper for inspection and maintenance.
- 12 When the damper installation is complete the operation of the damper should be checked.
- 13 Complete DW145 Fire Damper Certificate.

PRODUCT **0400FME**

APPLICATION **FLEXIBLE SUPPORTING CONSTRUCTION**

CLASSIFICATION REPORT NO. **TBA**

CLASSIFICATION **E120 (VE I ↔ O) S**

TESTED INSTALLATION METHOD SHOWN. DIFFERING INSTALLATION METHODS TO THIS MUST BE APPROVED BY THE BUILDING CONTROL AUTHORITY (BCA) BEFORE PROCEEDING.

FIRE & SMOKE – 0400FME CIRCULAR DAMPER IN RIGID SUPPORTING CONSTRUCTION

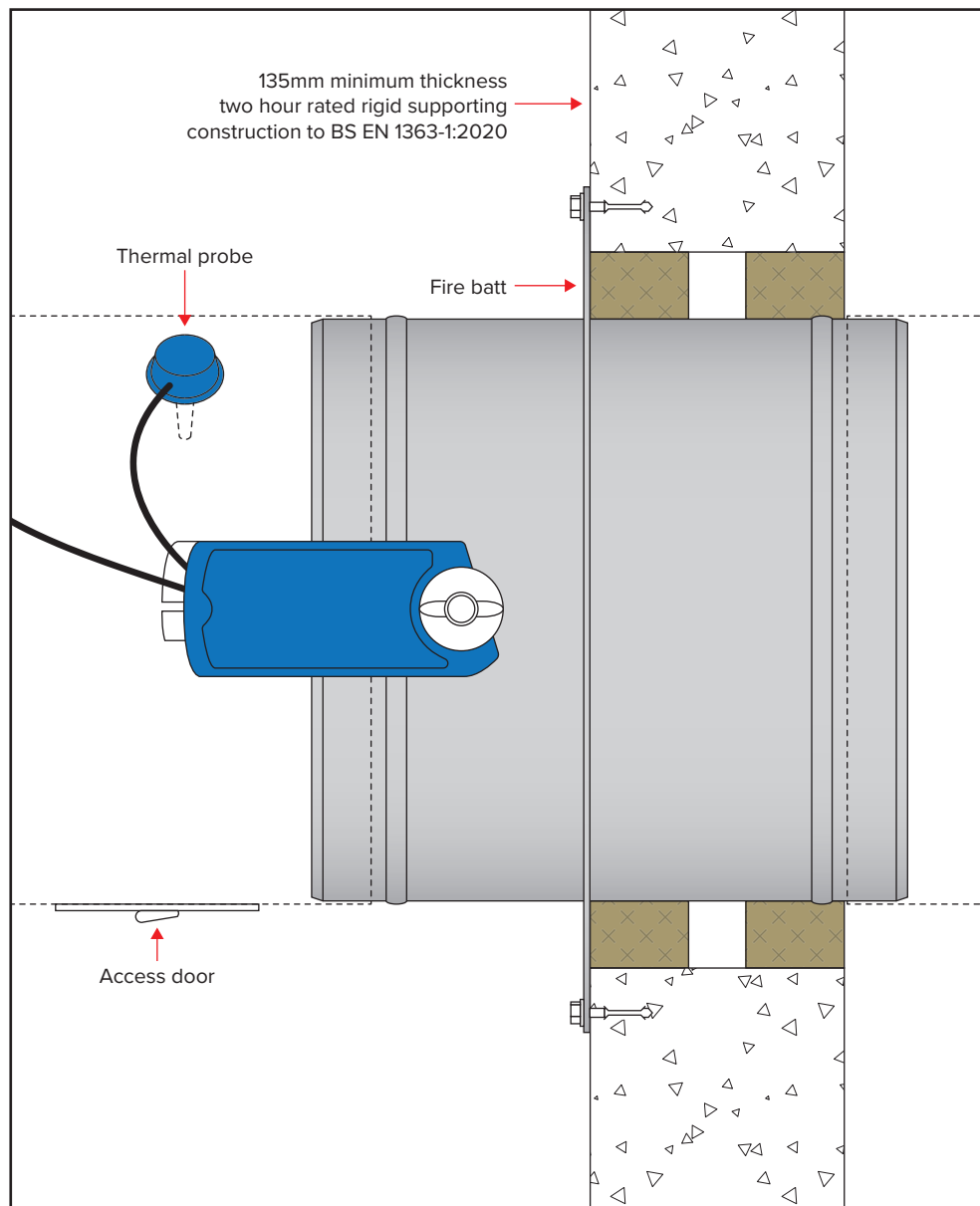

Preparation

- 1 Ensure that the damper is kept in a clean dry environment and that there is no damage to the damper.
- 2 Work out the opening size to be cut by adding 55mm to the duct diameter and cut a square hole to that size, see adjacent table.

| Nom. duct diameter | Opening size |
|--------------------|--------------|
| 100mm | 155 x 155mm |
| 125mm | 180 x 180mm |
| 150mm | 205 x 205mm |
| 160mm | 215 x 215mm |
| 200mm | 255 x 255mm |
| 250mm | 305 x 305mm |
| 300mm | 355 x 355mm |
| 315mm | 370 x 370mm |

Installation sequence

- 3 The damper should be mounted in the opening with the fixing flange (access side) flush with the wall.
- 4 Confirm that the blade is horizontal, and the actuator is on the RH or LH. The flange can then be secured to the wall using fire resistant steel fixings. Ensure that all the pre-drilled holes are populated.
- 5 The gap between the damper and the wall opening will need filling with two layers of 50mm thick 140kg/m³ fire batt cut to interference fit and pushed into place. All cut edges must be sealed with a fire batt sealant to BS EN 13501-2. A fire rated intumescent mastic to BS EN 13501-2 shall be applied to each joint.
- 6 The galvanised mild steel ductwork connecting to the damper spigots should overlap by 30mm, leaving a 10mm clearance for any duct expansion in a fire situation.
- 7 The galvanised mild steel ductwork connections must be sealed with an approved galvanised mild steel ductwork sealer and fixed with low resistance fixings such as aluminium rivets that will melt at high temperature allowing the duct to break away without affecting the integrity of the installation.
- 8 The thermal probe should be fitted in the connecting galvanised mild steel ductwork, up to 400mm away from the wall. Drill a 11mm hole, insert the thermal probe and secure with two pro points. Template and screws supplied.
- 9 The connecting galvanised mild steel ductwork must be independently supported within one metre of the connections and have been installed in accordance with DW144.
- 10 An access door should be fitted on the access side of the damper for inspection and maintenance.
- 11 When the damper installation is complete the operation of the damper should be checked.
- 12 Complete DW145 Fire Damper Certificate.

PRODUCT **0400FME**

APPLICATION **RIGID SUPPORTING CONSTRUCTION**

CLASSIFICATION REPORT NO. **TBA**

CLASSIFICATION **E120 (VE I ↔ O) S**

TESTED INSTALLATION METHOD SHOWN. DIFFERING INSTALLATION METHODS TO THIS MUST BE APPROVED BY THE BUILDING CONTROL AUTHORITY (BCA) BEFORE PROCEEDING.

Initial operating check

The 0400MAN damper should only be commissioned once the installation has been completed. The damper should be inspected thoroughly to ensure that it is clean and free of any internal debris before the damper actuation is tested as per the following instructions;

- Remove the access door.
- To operate the damper the thermal fuse must be unscrewed, then turn the handle anticlockwise until it is in the open position, as shown on the label.
- The damper blade is under tension from a spring so the handle must be held in position whilst the thermal fuse is re-tightened, the blade will hold in the open position.
- To ensure the damper is operating correctly the damper should be tested by first checking that there are no obstructions to the handle and that it is free to move. Then unscrew the thermal fuse quickly, this will release the blade to its closed position.
- Check that the blade is in the closed position by checking that the handle is in line with the close position on the label.
- If everything is satisfactory then reset the damper to its correct position, either fully open or if it is to balance air then this can be done so long as the damper remains at least 50% open.
- Re-fit the access door.
- If the damper has not closed, the blade may have been incorrectly positioned, or the damper may be faulty. Please contact Advanced Air for advice.

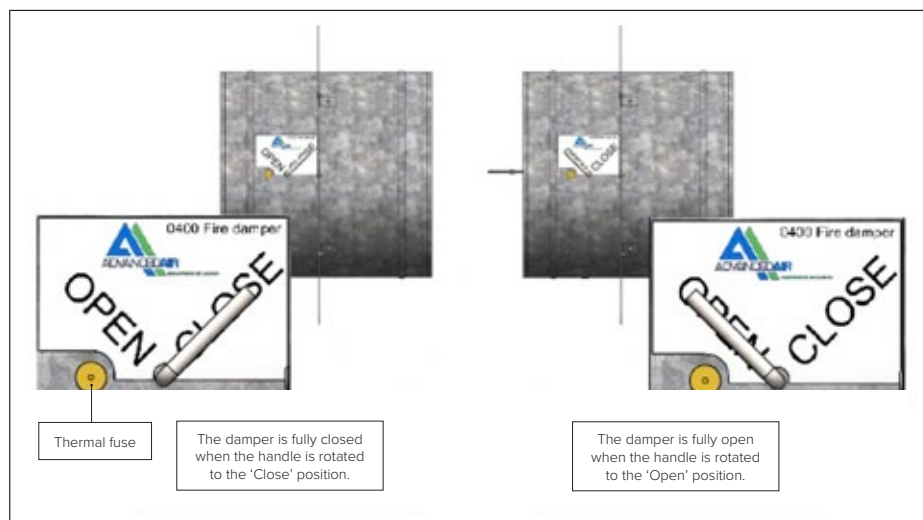

Maintenance

0400MAN dampers are installed as a life safety product and it is essential that they are always maintained in good, clean working condition. In accordance with BS9999 Annex W.1 maintenance and inspection should be undertaken annually.

Maintain the dampers as follows;

- Mark the handle position on the label so that it can be reset to the same position after testing.
- Remove the access door.
- Visually inspect all damper components for signs of corrosion, obstructions and build-up of dirt/dust.
- Remove any obstructions, wipe away all dirt/dust from the damper blades and duct surfaces.
- After internal inspections are complete a functional check of the damper should be made.
- Test the damper by unscrewing the thermal fuse quickly, check that it reaches its closed position.
- Reset the damper to its original position and re-tighten the fusible link.
- If there is a requirement to change the thermal fuse this can be done simply by unscrewing it fully from the case and replacing with a new one. The thermal fuse should be replaced if it has been activated, damaged or part of a regular service plan.
- Refit the access door and complete inspection reports as appropriate.

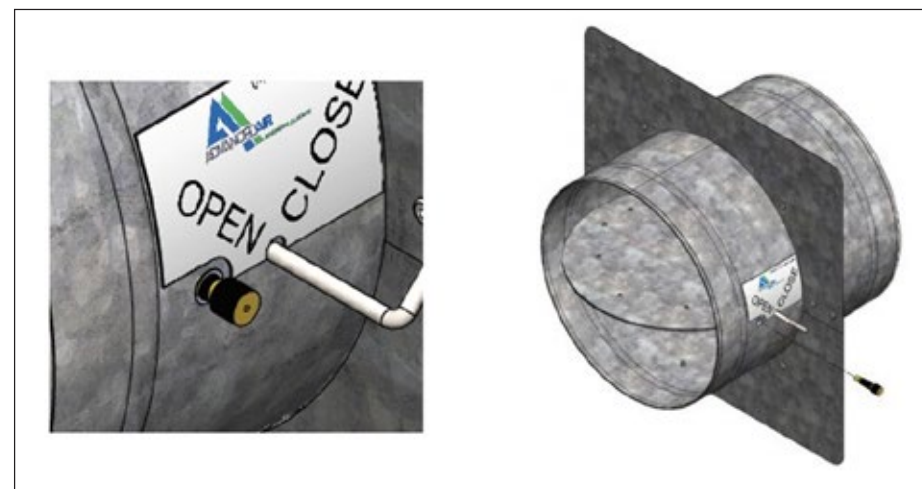

Initial operating check

The 0400FME damper should only be commissioned once it is fully installed and connected to electrical power. The damper should be inspected thoroughly to ensure that it is clean and free of any internal debris before the damper actuation is tested as per the following instructions:

- Isolate the power.
- Remove the access door.
- Test the damper manually by using the Allen key provided and turning it clockwise until the damper is fully opened, mechanically lock the actuator by using a screwdriver to turn the **STOP SHAFT** 5°.
- Visually inspect the damper checking that the damper is in its fully opened position.
- Close the damper by turning the Allen key clockwise and releasing it, the spring action of the actuator will wind the damper to its fully closed position.
- Visually inspect the damper checking that the damper is in its fully closed position.
- Reapply power to the actuator. The actuator will start to travel, and a **GREEN** light will be lit on the Thermal Release housing, it will take 90 seconds to fully open.
- The switch on the Thermal Release housing can be pressed to simulate activation of the thermal release, the LED light will turn **RED** and the actuator will spring return to its unpowered position, it should take 15 seconds to complete this cycle.
- Release the switch and the damper will return to its fully opened position.
- Visually inspect through the access door that the blades are fully open and then re-fit the access door.
- Damper not fully opening or closing?
 - Obstruction to the blades – remove the obstruction.
 - Incorrect set up of the actuator – the actuator has been adjusted by others from the Factory Set position.
 - For other faults contact Advanced Air Sales Office.
- Complete any relevant reports.

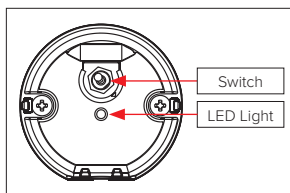
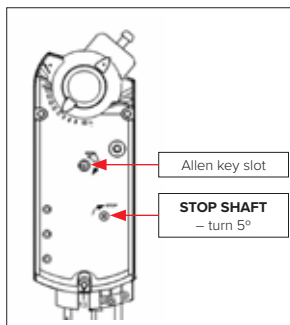

Maintenance

0400FME dampers are installed as a life safety product and it is essential that they are always maintained so they are in a clean working condition. In accordance with BS9999 Annex W.1 maintenance and inspection should be undertaken annually.

Maintain the dampers as follows;

- Remove the access door to internally inspect the damper.
- Visually inspect all damper components for signs of corrosion, obstructions and build-up of dirt/dust.
- Remove any obstructions, wipe away all dirt and dust from the damper blades and duct surfaces.
- Check that the thermal release probe is intact and does not show signs of damage.
- After internal inspections are complete a functional check of the damper should be made.
- The 0400FME damper is fitted with an electrical thermal release probe and its housing has a LED light and an On/Off toggle switch.
 - A **GREEN** light indicates that there is a power supply and that the thermo sensor is OK.
 - A **RED** light indicates a power supply but there is a fault.
 - No light indicates that there is no power supply.

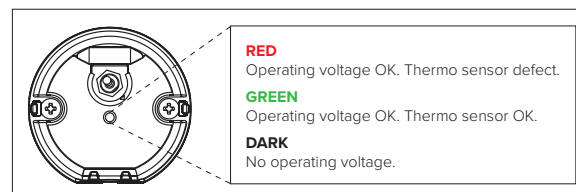

- Push and hold the toggle switch to simulate over-temperature. This simulates the response of the thermal release, enabling the proper functioning test of the actuator and damper. It will take 15 seconds for the damper to close and during the test the LED light will turn **RED**.
- After checking that the blades on the damper are fully closed, release the switch and the actuator will power to its open position and the light will turn **GREEN**, check the blades are in the open position.
- Refit the access door and complete maintenance reports as appropriate.

WIRING INSTRUCTIONS – 0400FME

Wiring detail for dampers fitted with spring return actuators AA230TS4 or AA24TS4.

| Actuator power consumption: | | | |
|-----------------------------|---------|---------|--------------|
| AA230TS4 | 230V AC | Running | 7 VA / 4.5 W |
| | | Holding | 3.5 W |
| AA24TS4 | 24V AC | Running | 5 VA / 3.5 W |
| | | Holding | 2 W |
| AA24TS4 | 24V DC | Running | 3.5 W |
| | | Holding | 2 W |

| Damper position signal volt free contacts rating: | |
|---|---------------------|
| AC | 24...230 V / 2 Amps |
| DC | 12...30 V / 2 Amps |

Input power to damper
(Voltage stated on actuator)
For power consumption see table above

Damper position signals
(volt free contacts)
For rating see table above

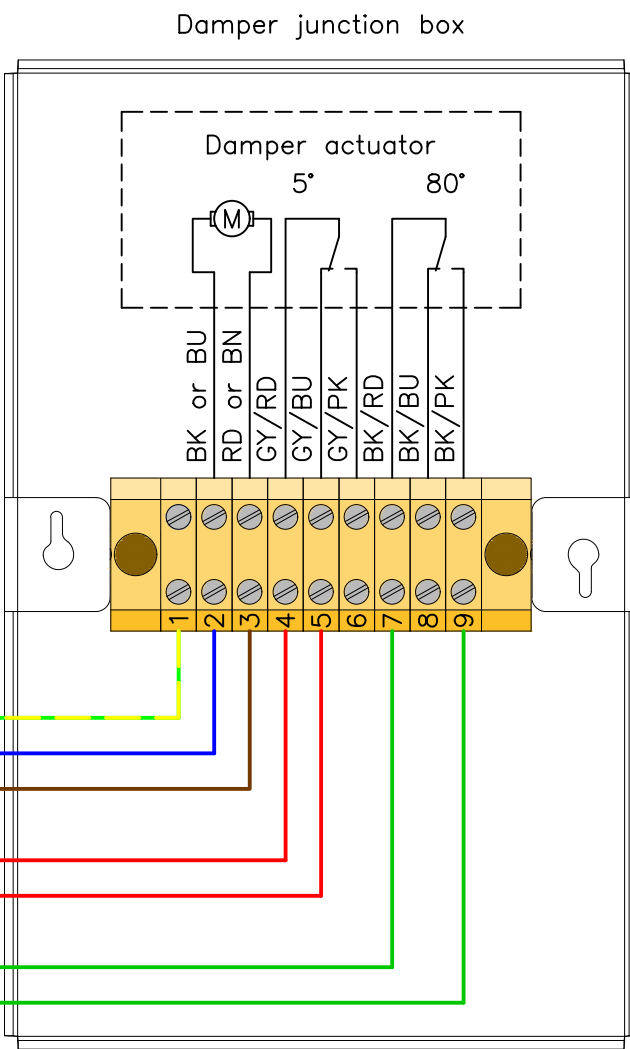

SPACING AROUND DAMPER INSTALLATIONS

Supporting construction

BS EN 1366-2:2015 section 7.3 states “the distance between the fire dampers shall not normally be less than 200mm, as shown in Figures 11 and 12.” Hence a minimum of 200mm supporting construction is required.

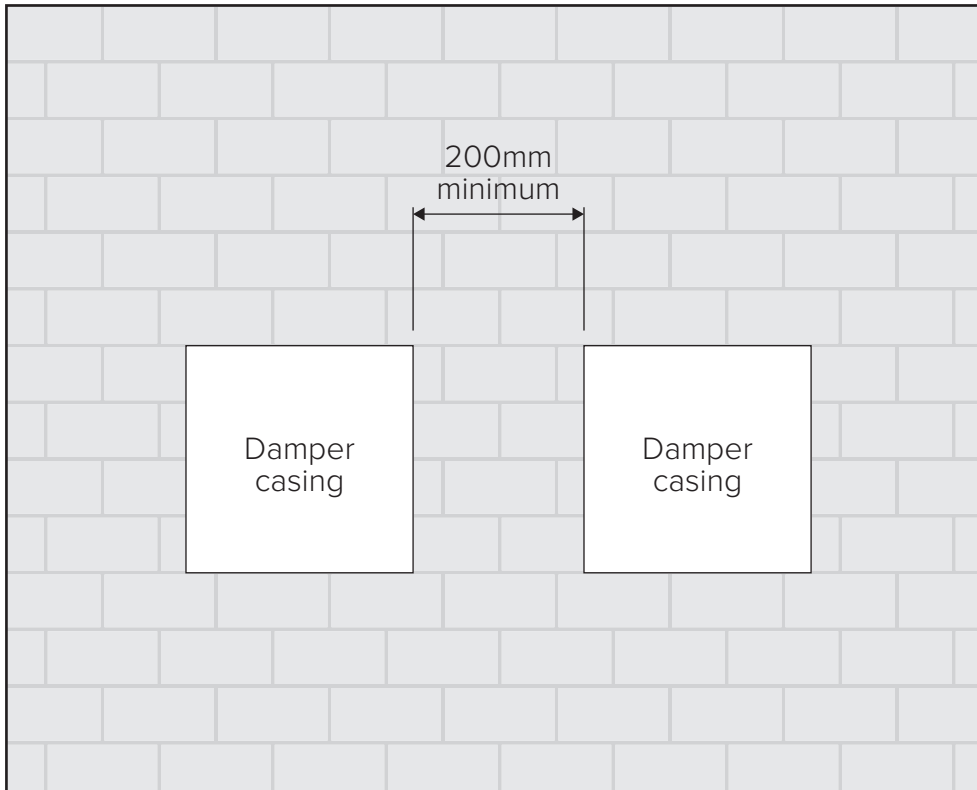

Surrounding construction

BS EN 1366-2:2015 section 13.6 states “minimum separation of 75mm between fire damper and a construction element (wall /floor).”

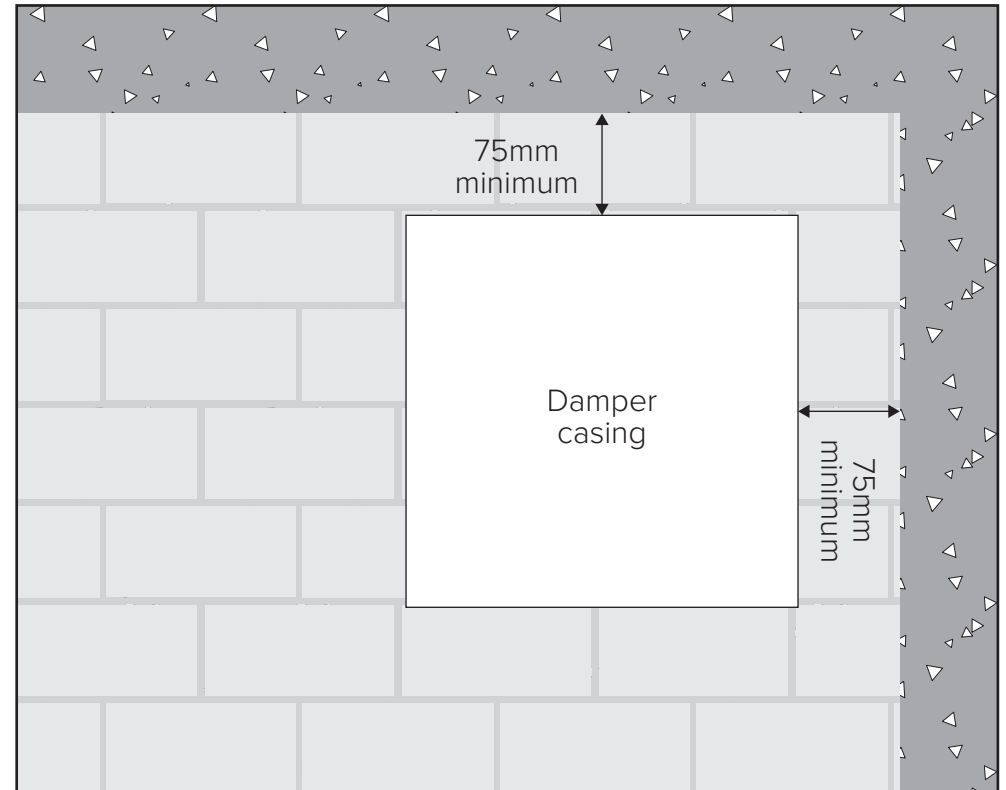

Multiple ducts in one large opening is not currently included in a harmonised standard, but this is being investigated by standards committees.

Fire Damper Certificate

DW 145 Inspection & Handover Check Sheet to be completed by the installer with a separate certificate for each damper.

| No. | Question | Guidelines | Tick |
|-----|--|---|------|
| 1 | Are the dampers the correct type? | Fire Damper Model 0160, 0400MAN Fire Damper Model 2550, 2530, 26SCD and 0400FME | |
| 2 | Are the dampers correctly identified? | Identification label clearly shows the damper individual reference number | |
| 3 | Are the dampers located correctly? | The damper position matches the position as detailed on the manufactures installation instructions | |
| 4 | Have supports for both the damper and the adjacent ductwork been installed in accordance with the approved method? | | |
| 5 | Are the dampers fitted in the correct orientations? | The dampers are installed the correct way up relative to airflow and access | |
| 6 | Is access, through the ductwork to the damper unobstructed? | There is unobstructed space to allow safe access to damper, also through ceiling void and adjacent services | |
| 7 | Confirm the space around the damper has not been used for the passage of other services | The presence of other services will invalidate the installation method | |
| 8 | Using the access opening provided, confirm that the damper has been left in the open position | | |
| 9 | Release the damper catch to simulate the thermal release mechanism (damper drop test) | Ensure the blade operation is free from interference | |
| 10 | Check damper blades for damage | With the damper in the closed position inspect for damage | |
| 11 | Re-set damper and replace access panel | After resetting check that if supplied the visual position indicator is correct | |
| 12 | Is the fire barrier and penetration seal complete? | Confirm at handover if installation is complete and if no then other trades will be required to finish | |
| 13 | Handover damper installation for commissioning | Obtain relevant acceptance of the damper installation from the nominated person responsible | |

| | | |
|---------------|--|--|
| Project | Installer Name | |
| Damper ID No: | Company | |
| Location | Date | |
| Type | I hereby confirm the damper detailed has been installed and tested according to the manufactures recommendations | |
| Model No: | Signature | |