

0400 CIRCULAR FIRE DAMPER

Declaration of Performance (DoP)

Complying with the Construction Product Regulations 2020, UK Statutory Instruments 2020 No. 1359 of Ministry of Housing, Communities and Local Government.



INTENDED USE	Fire safety
HARMONISED STANDARD	BS EN 15650
MANUFACTURER	Advanced Air (UK) Ltd Burrell Way, Thetford, Norfolk IP24 3QU Email projects@advancedair.co.uk Web www.advancedair.co.uk Tel 01842 765 657
SYSTEM OF ASSESSMENT AND VERIFICATION OF CONSTANCY OF PERFORMANCE	System 1
NOTIFIED BODY	The notified body 0832 – BRE carried out the initial inspection of the manufacturing plant and of the production control as well as the continuous surveillance and evaluation of the factory production control according to System 1 of the Construction Products Regulation.
CERTIFICATE OF CONSTANCY OF PERFORMANCE	0832-UKCA-CPR-P1003 issued on 12 nd November 2021.

CONSTRUCTION PRODUCT	FIRE DAMPERS		
Intended Use	To be used in conjunction with partitions to maintain fire compartments in heating, ventilation and air conditioning installations.		
ESSENTIAL CHARACTERISTICS	REQUIREMENT CLAUSES IN BS EN 15650	PERFORMANCE LEVEL ACHIEVED	NOTES
Nominal activation conditions/sensitivity:	4.2.1.2		
Sensing element load bearing capacity	4.2.1.2.2	Pass	
Sensing element response temperature	4.2.1.2.3		
Response delay time	4.2.2.2	Pass	
Operation reliability – Cycling	4.3.1 (a)	Pass	50 cycles
FIRE RESISTANCE			
– Integrity	4.1.1 (a)	E	120 minutes
– Insulation	4.1.1 (b)	EI	No Performance Declared
– Smoke leakage	4.1.1 (c)	ES	120 minutes
– Mechanical stability (under E)	4.1.1 (a)	Pass	
– Maintenance of cross section (under E)	4.1.1 (a)	Pass	
DURABILITY			
-of response delay	4.2.1.2.2 & 4.2.1.2.3	Pass	
-of operation reliability	4.3.3.2	Pass	10,000 cycles – Pass

Signed on behalf of Advanced Air (UK) Ltd:

Andrew Sargent
Managing Director
16th November 2022



0400MAN CIRCULAR FIRE DAMPER

Declaration of Performance (DoP)

Complying with EU Regulation: 305/2011/EEC Construction Products Regulation

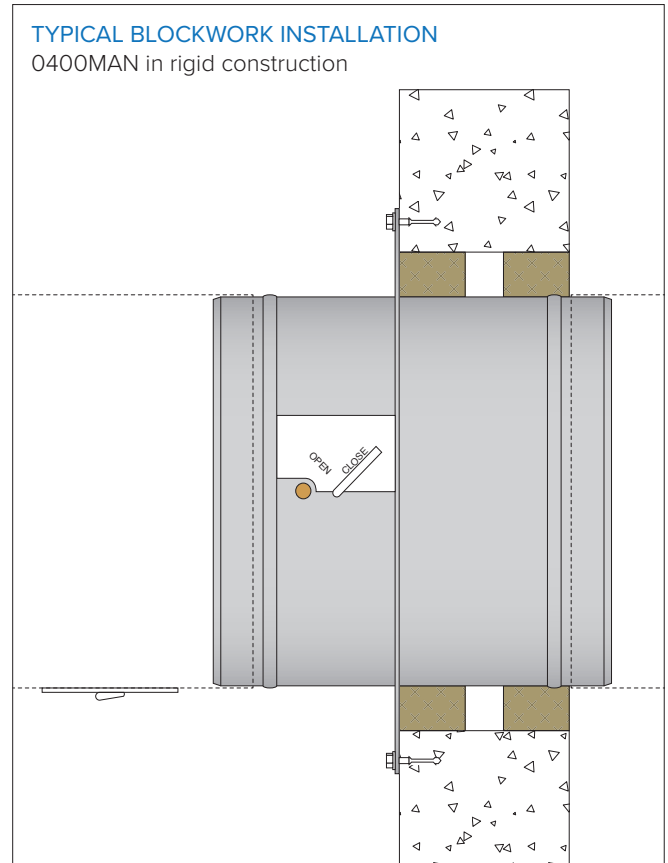
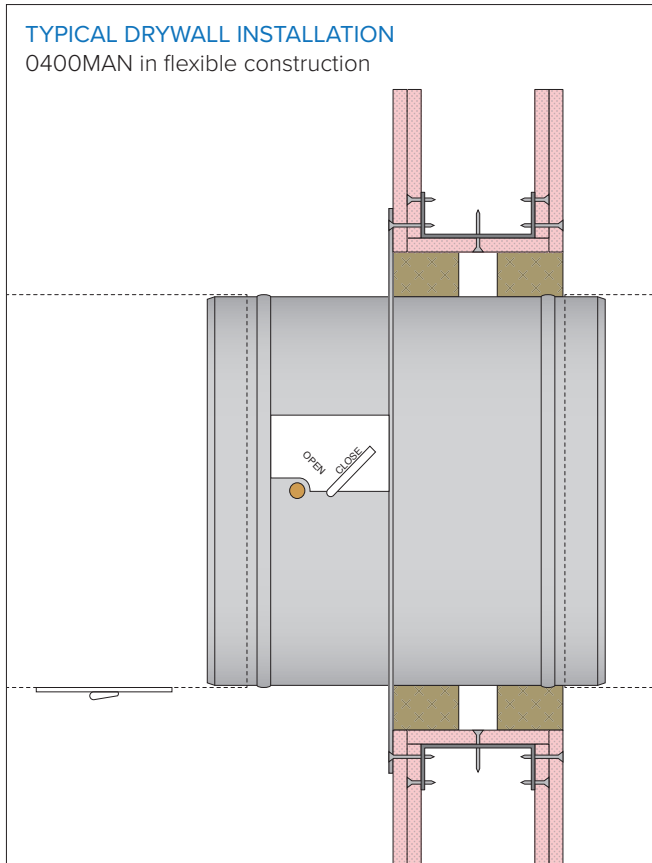

0400MAN IN 1 HOUR WALL – FLEXIBLE CONSTRUCTION (DRYWALL)

Size	Installation method	Supporting construction	Report no.	Date	Performance classification
100m diameter minimum, 315mm diameter maximum	Flange (surface of wall)	Types B and C Minimum 106mm thickness	EFR-21-000588	24/06/21	E60 (ve i ↔ o) s

0400MAN IN 2 HOUR WALL – FLEXIBLE CONSTRUCTION (DRYWALL)

Size	Installation method	Supporting construction	Report no.	Date	Performance classification
100m diameter minimum, 315mm diameter maximum	Flange (surface of wall)	Types B and C Minimum 131mm thickness	EFR-21-000588	24/06/21	E120 (ve i ↔ o)

0400MAN IN 1 HOUR WALL – RIGID CONSTRUCTION (BLOCKWORK / CONCRETE)

Size	Installation method	Supporting construction	Report no.	Date	Performance classification
100m diameter minimum, 315mm diameter maximum	Flange (surface of wall)	Minimum 106mm thickness	EFR-21-000588	24/06/21	E60 (ve i ↔ o) s

0400MAN IN 2 HOUR WALL – RIGID CONSTRUCTION (BLOCKWORK / CONCRETE)

Size	Installation method	Supporting construction	Report no.	Date	Performance classification
100m diameter minimum, 315mm diameter maximum	Flange (surface of wall)	Minimum 131mm thickness	EFR-21-000588	24/06/21	E120 (ve i ↔ o)

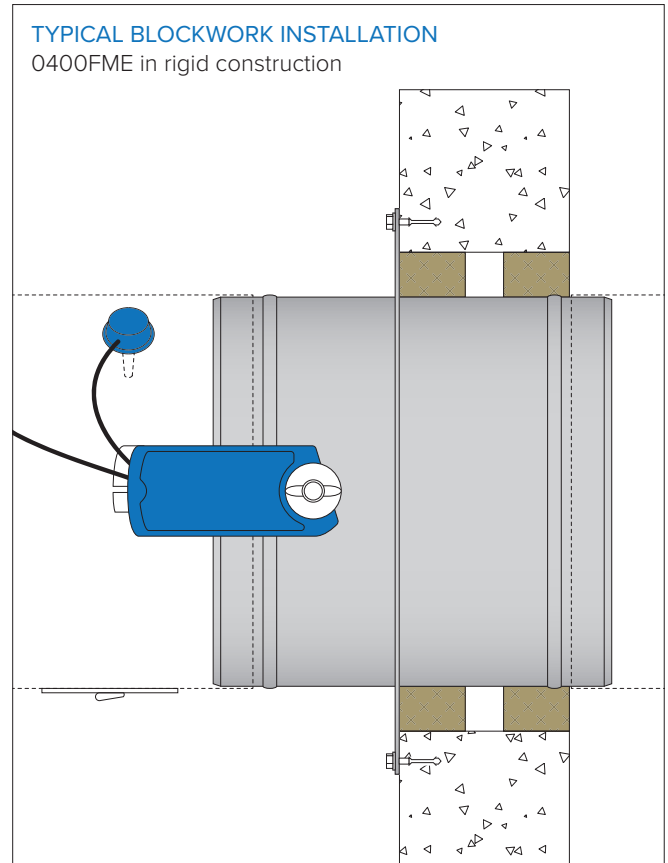
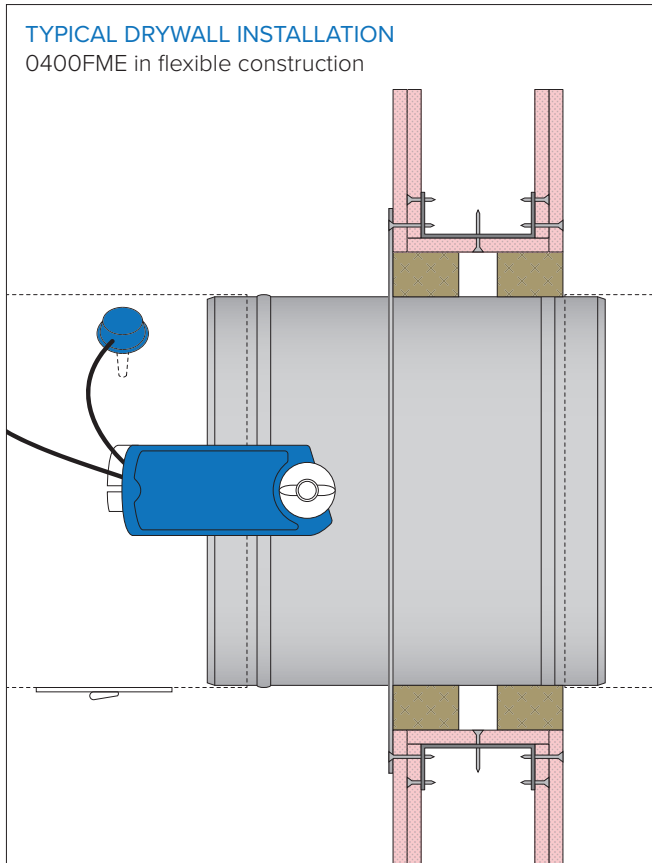

0400FME IN 1 HOUR WALL – FLEXIBLE CONSTRUCTION (DRYWALL)

Size	Installation method	Supporting construction	Report no.	Date	Performance classification
100m diameter minimum, 315mm diameter maximum	Flange (surface of wall)	Types B and C Minimum 106mm thickness	EFR-21-000588	24/06/21	E60 (ve i ↔ o) s

0400FME IN 2 HOUR WALL – FLEXIBLE CONSTRUCTION (DRYWALL)

Size	Installation method	Supporting construction	Report no.	Date	Performance classification
100m diameter minimum, 315mm diameter maximum	Flange (surface of wall)	Types B and C Minimum 131mm thickness	EFR-21-000588	24/06/21	E120 (ve i ↔ o) s

0400FME IN 1 HOUR WALL – RIGID CONSTRUCTION (BLOCKWORK / CONCRETE)

Size	Installation method	Supporting construction	Report no.	Date	Performance classification
100m diameter minimum, 315mm diameter maximum	Flange (surface of wall)	Minimum 106mm thickness	EFR-21-000588	24/06/21	E60 (ve i ↔ o) s

0400FME IN 2 HOUR WALL – RIGID CONSTRUCTION (BLOCKWORK / CONCRETE)

Size	Installation method	Supporting construction	Report no.	Date	Performance classification
100m diameter minimum, 315mm diameter maximum	Flange (surface of wall)	Minimum 131mm thickness	EFR-21-000588	24/06/21	E120 (ve i ↔ o) s